

Technical details

Operating pressure	1 ... 10 bar
Temperature range	-20°C ... +80°C (0 ... +150°C for high temperature version)
Max. stroke	1000 mm
Medium	Filtered, oil-free and dried compressed air according to ISO 8573-1:2010, Class 7:2:4, instrument air, free of aggressive additives. Alternatively the pressure dew point must be at least 10°C below lowest occurring ambient temperature.
Materials	Cylinder tube: AISI 304 (1.4301) or AISI 316 (1.4401) End caps: AISI 304 (1.4301) or AISI 316 (1.4401) Piston rod: AISI 304 (1.4301) or AISI 316 (1.4401) Seals: PU, NBR, PBT, PTFE
	Cylinders in accordance with 2014/34/EU (ATEX) available. (Chapter 13)



Double acting pneumatic cylinder with adjustable cushions and magnetic piston for proximity sensors.

Versions

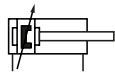

000, 002, 004, 0V0, 0V2, 0V4
double acting, adjustable cushioning,
with magnetic piston

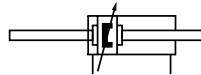

400, 403, 404, 4V0, 4V2, 4V4
double acting, double end piston rod, adjustab-
le cushioning, with magnetic piston

Order code

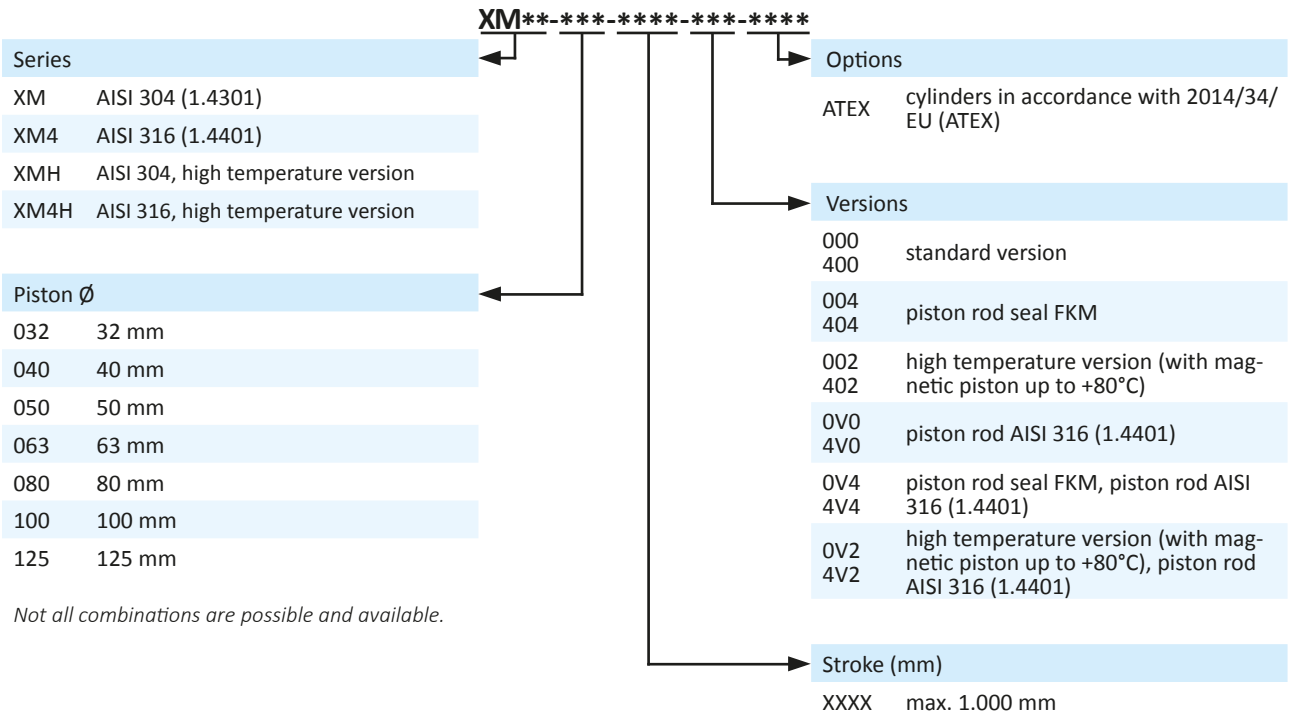

Series XM

ISO 15552, double acting



Technical data

Model-no.:	XM-032-...	XM-040-...	XM-050-...	XM-063-...	XM-080-...	XM-100-...	XM-125-...
Piston \varnothing (mm)	32	40	50	63	80	100	125
Force at 6 bar (N)	Extension	434	678	1060	1682	2713	4239
	Retraction	373	570	890	1513	2448	3974
Connection	G1/8	G1/4	G1/4	G3/8	G3/8	G1/2	G1/2
Piston rod thread	M10 x 1.25	M12 x 1.25	M16 x 1.5	M16 x 1.5	M20 x 1.5	M20 x 1.5	M27 x 2
Cushioning length (mm)	20	22	25	25	35	35	35

Dimensions series XM (Versions: -000 and -010)

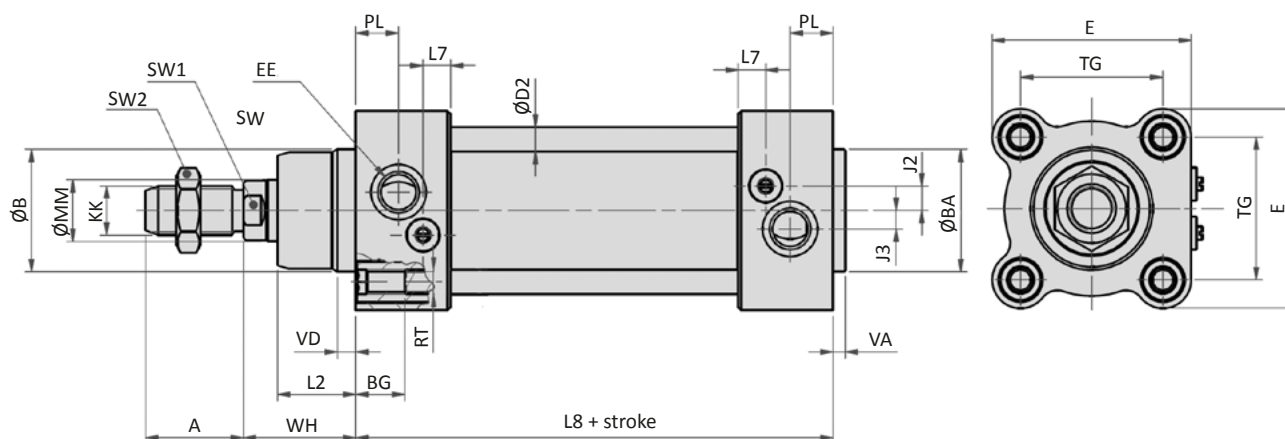

Piston \varnothing	A	\varnothing B	\varnothing BA	BG	\varnothing D2	E	EE	J2	J3	KK	L2
32	22	30	30	16	6	48	G1/8	6.6	5.3	M10 x 1.25	18
40	24	35	35	16	6	52	G1/4	8.5	5	M12 x 1.25	22
50	32	40	40	16	8	65	G1/4	8	6	M16 x 1.5	25.5
63	32	45	45	16	8	75	G3/8	10	6.5	M16 x 1.5	26
80	40	45	45	18	10	95	G3/8	8	8	M20 x 1.5	32
100	40	55	55	18	10	115	G1/2	15	7	M20 x 1.5	38
125	54	60	60	20	12	140	G1/2	13	7	M27 x 2	46

Piston \varnothing	L7	L8	\varnothing MM	PL	RT	SW1	SW2	TG	VA	VD	WH
32	7.2	94	12	13	M6	10	17	32.5	4	5	26
40	9.2	105	16	14	M6	13	19	38	4	5	30
50	9	106	20	14	M8	17	24	46.5	4	6	37
63	9.5	121	20	16	M8	17	24	56.5	4	6	37
80	11	128	25	16	M10	22	30	72	4	7	46
100	12	138	25	18	M10	22	30	89	4	7	51
125	12	160	32	18	M12	27	41	110	6	10	65

Piston \varnothing (mm)	32	40	50	63	80	100	125
Weight (kg)	0.960	1.455	2.370	2.550	6.030	9.420	14.550
each 100 mm stroke	0.240	0.290	0.430	0.480	1.050	1.200	2.200

Dimensions series XM (addition at double end piston rod)

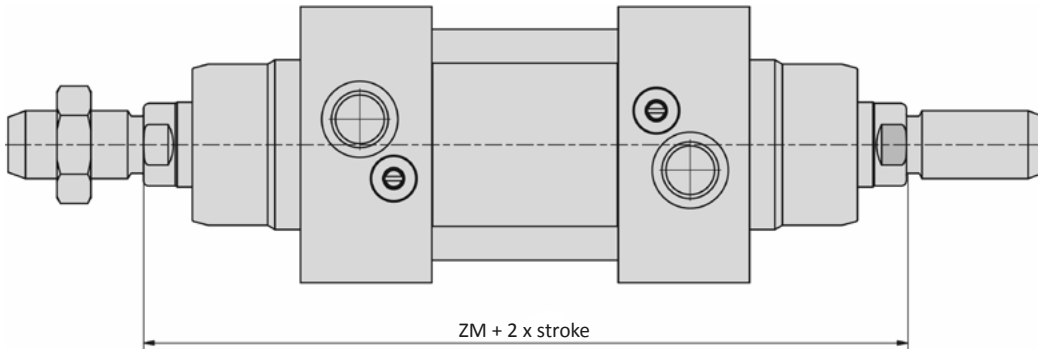

Piston Ø (mm)	32	40	50	63	80	100	125
ZM	146	165	180	195	220	240	290

Piston Ø (mm)	32	40	50	63	80	100	125
Weight (kg)							
0 mm stroke	1.086	1.615	2.677	3.930	6.561	10.180	15.868
each 100 mm stroke	0.330	0.480	0.810	0.850	1.440	1.930	2.920

Series XM
Mounting accessories



CXM-xxx-01 Foot mount

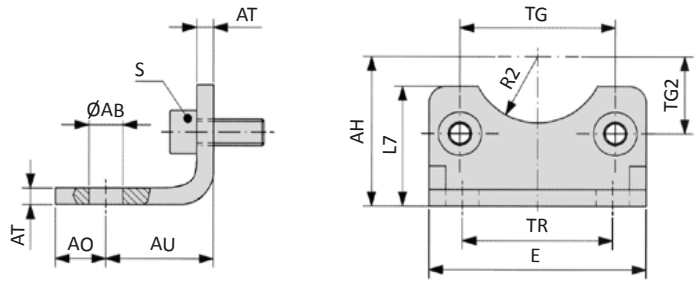
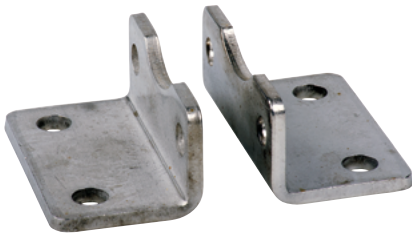

Model-no.:	Ø AB	AH	AO	AU	AT	E	L7	R2	S	TG	TG2	TR
CXM-032-01	7	32	11	24	4	45	30	15	M6 x 20	32.5	16.25	32
CXM-040-01	10	36	8	28	4	52	30	17.5	M6 x 20	38	19	36
CXM-050-01	10	45	15	32	5	65	36	20	M8 x 20	46.5	23.25	45
CXM-063-01	10	50	13	32	5	75	35	22.5	M8 x 20	56.5	28.25	50
CXM-080-01	12	63	14	41	6	95	47	22.5	M10 x 20	72	36	63
CXM-100-01	14.5	71	16	41	6	115	53	27.5	M10 x 20	89	44.5	75
CXM-125-01	16.5	90	25	45	8	140	70	30	M12 x 25	110	55	90

Material: stainless steel AISI 304 (1.4301); 2 x 2 screws in accordance with EN ISO 4762 are included.

CXM-xxx-02 Flange mount

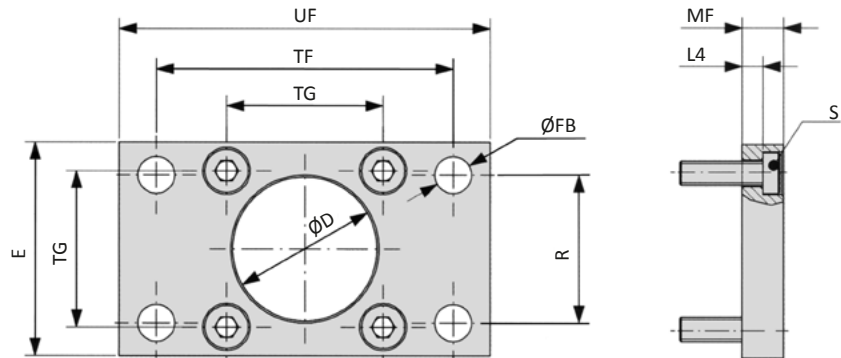
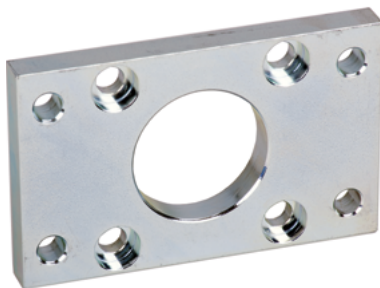

Model-no.:	Ø D	E	Ø FB	L4	MF	R	S	TF	TG	UF
CXM-032-02	30	45	7	5	10	32	M6 x 20	64	32.5	80
CXM-040-02	35	52	9	5	10	36	M6 x 20	72	38	90
CXM-050-02	40	65	9	6.5	12	45	M8 x 20	90	46.5	110
CXM-063-02	45	75	9	6.5	12	50	M8 x 20	100	56.5	120
CXM-080-02	45	95	12	9	16	63	M10 x 25	126	72	150
CXM-100-02	55	115	14	9	16	75	M10 x 25	150	89	170
CXM-125-02	60	140	16	10.5	20	90	M12 x 25	180	110	205

Material: stainless steel AISI 304 (1.4301); 2 x 2 screws in accordance with DIN 7984 are included.

CXM-xxx-03 Clevis mount



Inclusive clevis pin
order no: **CXM-xxx-38**

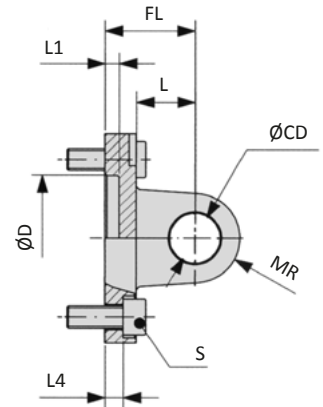
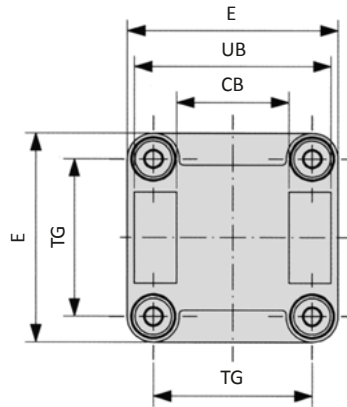

Model-no.:	CB	Ø CD	Ø D	E	FL	L	L1	L4	MR	S	TG	UB
CXM-032-03	26	10	30	45	22	13	5	5.5	10	M6 x 20	32.5	45
CXM-040-03	28	12	35	52	25	16	5	5.5	12	M6 x 20	38	52
CXM-050-03	32	12	40	65	27	16	5	6.5	12	M8 x 20	46.5	60
CXM-063-03	40	16	45	75	32	21	5	6.5	16	M8 x 20	56.5	70
CXM-080-03	50	16	45	95	36	22	5	10	16	M10 x 25	72	90
CXM-100-03	60	20	55	115	41	27	5	10	20	M10 x 25	89	110
CXM-125-03	70	25	60	140	50	30	7	10	25	M12 x 25	110	130

Material: stainless steel AISI 304 (1.4301); 4 screws in accordance with EN ISO 4762 are included.

CXM-xxx-05 Swivel mount

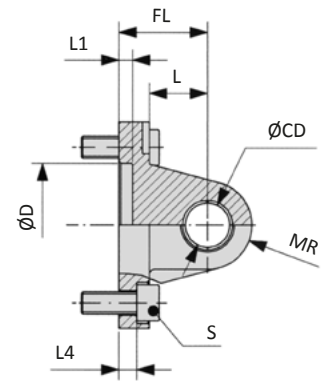
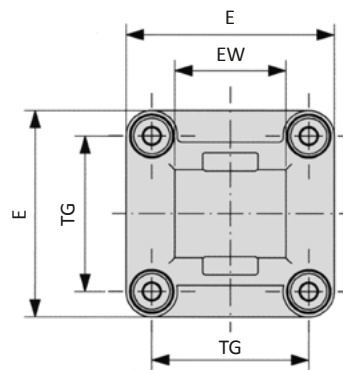
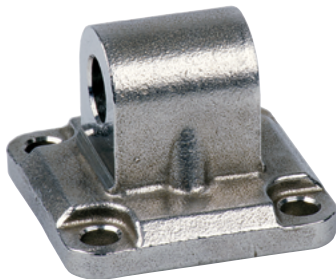

Model-no.:	Ø CD	Ø D	E	EW	FL	L	L1	L4	MR	S	TG
CXM-032-05	10	30	45	26	22	13	5	5.5	10	M6 x 20	32.5
CXM-040-05	12	35	52	28	25	16	5	5.5	12	M6 x 20	38
CXM-050-05	12	40	65	32	27	16	5	6.5	12	M8 x 20	46.5
CXM-063-05	16	45	75	40	32	21	5	6.5	16	M8 x 20	56.5
CXM-080-05	16	45	95	50	36	22	5	10	16	M10 x 25	72
CXM-100-05	20	55	115	60	41	27	5	10	20	M10 x 25	89
CXM-125-05	25	60	140	70	50	30	7	10	25	M12 x 25	110

Material: stainless steel AISI 304 (1.4301); 4 screws in accordance with EN ISO 4762 are included.

Series XM Mounting accessories



CXM-xxx-06 Swivel mount 90°

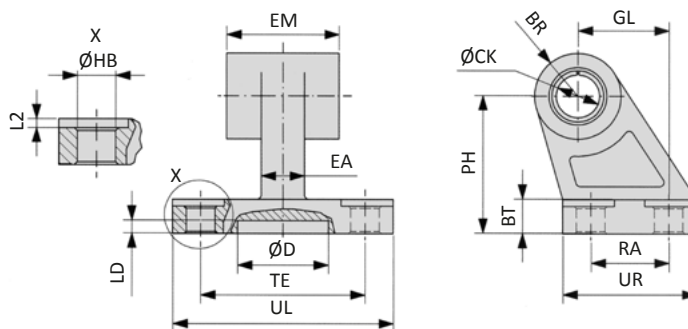

Model-no.:	BR	BT	ØCK	Ø D	EA	EM	GL	ØHB	L2	LD	PH	RA	TE	UL	UR
CXM-032-06	10	8	10	21	10	26	21	6.6	1.6	3	32	18	38	51	31
CXM-040-06	11	10	12	21	15	28	24	6.6	1.6	3	36	22	41	54	35
CXM-050-06	13	12	12	21	16	32	33	9	1.6	3	45	30	50	65	45
CXM-063-06	15	14	16	21	16	40	37	9	1.6	3	50	35	52	67	50
CXM-080-06	15	14	16	21	20	50	47	11	2.5	3	63	40	66	86	60
CXM-100-06	19	17	20	11	20	60	55	11	2.5	3	71	50	76	96	70
CXM-125-06	22.5	20	25	21	30	70	70	14	3.2	3	90	60	94	124	90

Material: stainless steel AISI 304 (1.4301)

CXM-xxx-08 Clevis pin

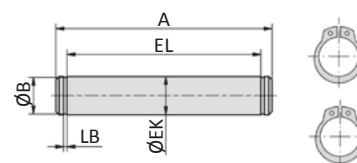

Model-no.:	A	Ø B	Ø EK	EL	LB
CXM-032-08	53	9.6	10	46	1.1
CXM-040-08	60	11.5	12	53	1.1
CXM-050-08	68	11.5	12	61	1.1
CXM-063-08	78	15.2	16	71	1.1
CXM-080-08	98	15.2	16	91	1.1
CXM-100-08	118	19	20	111	1.3
CXM-125-08	139	23.9	25	132*	1.3

Material: stainless steel AISI 304 (1.4301); 2 snap rings are included.

PD-xx Rod clevis

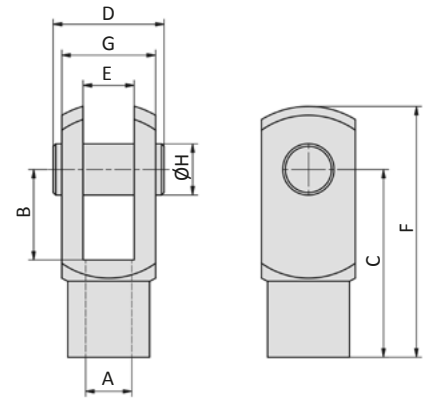

Model-no.:	for cylinder	A	B	C	D	E	F	G	Ø H
PD-25	XM-032	M10 x 1.25	20	40	26	10	52	20	10
PD-40	XM-040	M12 x 1.25	24	48	32	12	62	24	12
PD-63	XM-050, XM-063	M16 x 1.5	32	64	40	16	83	32	16
PD-80	XM-080, XM-100	M20 x 1.5	40	80	50	20	105	40	20

Material: stainless steel AISI 303 (1.4305)

PO-xx Rod eye

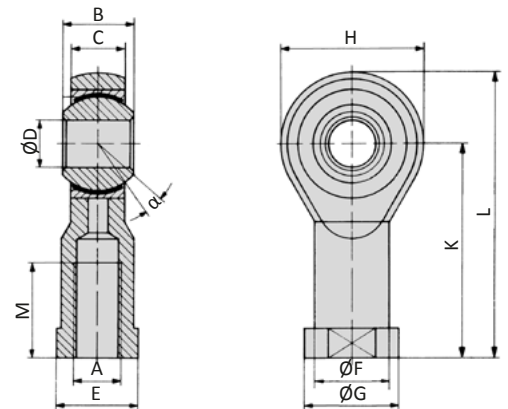

Model-no.:	for cylinder	A	B	C	Ø D	E	Ø F	Ø G	H	K	L	M	α
PO-25	XM-032	M10 x 1.25	14	10.5	10	17	15	19	28	43	57	20	13°
PO-40	XM-040	M12 x 1.25	16	12	12	19	17.5	22	32	50	66	22	13°
PO-63	XM-050, XM-063	M16 x 1.5	21	15	16	22	22	27	42	64	85	28	15°
PO-80	XM-080, XM-100	M20 x 1.5	25	18	20	30	27.5	34	50	77	102	33	14°

Materials: stainless steel AISI 331 (1.4057), bearing stainless steel AISI 316 Ti, PTFE coated, bushing stainless steel AISI 420 (1.4034)

Proximity sensors

