

Series T-25

Technical details

Connection	M5
Nominal size	2.5 mm
Temperature range	-10°C ... +70°C
Medium	Filtered, oil-free and dried compressed air according to ISO 8573-1:2010, Class 7:2:4, instrument air, free of aggressive additives. Alternatively the pressure dew point must be at least 10°C below lowest occurring ambient temperature.
Materials	Body: Al (anodized), seals: NBR, inner parts: stainless steel and brass, stem: stainless steel



Mechanically operated seat valve including mounting adapter for actuator installation.

3/2-way valve

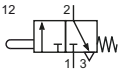

T-25-311
3/2-way, mechanical spring return,
stem operated

Technical data

Model-no.:	T-25-311
Operating pressure (bar)	0 ... 12
Flow rate (NI/min)	95
Actuating force at 6 bar (N)	22
Actuation stroke (mm)	4
Weight (kg)	0.042

Dimensions

T-25-311

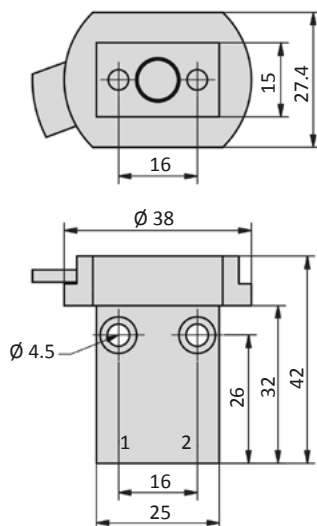

- 1 = pressure inlet
2 = outlet